



## 一级代理商：

深圳市弗瑞鑫电子有限公司

地址：深圳市宝安区西乡大道302号金源商务大厦B座三楼

frxelec

---

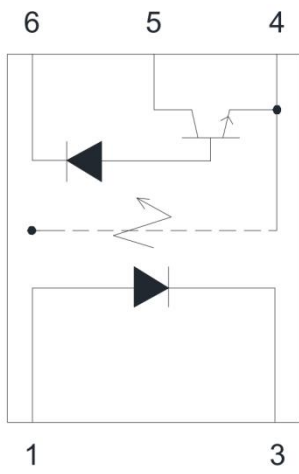

- 1. Anode
- 3. Cathode
- 4. GND
- 5. Vo (Output)
- 6. Vcc

( )	



---

---

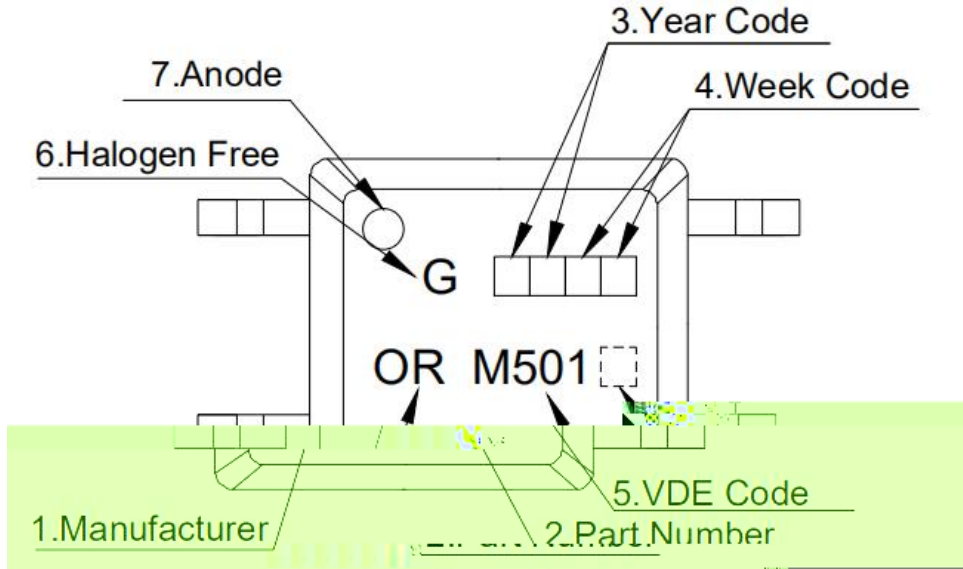

□□ :

□□ :

□□

( )

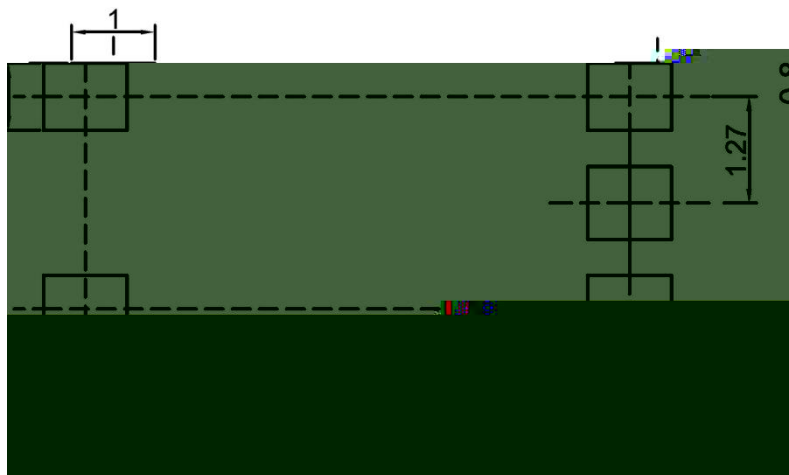
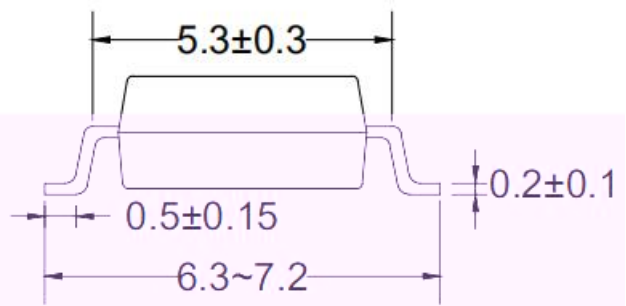
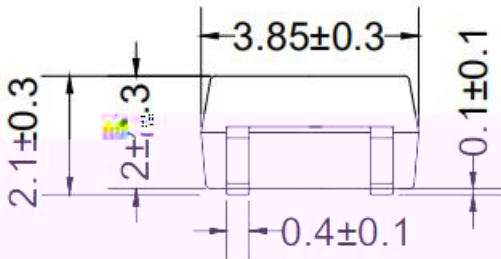
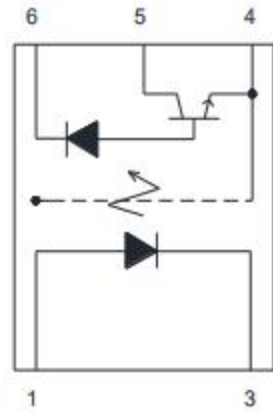
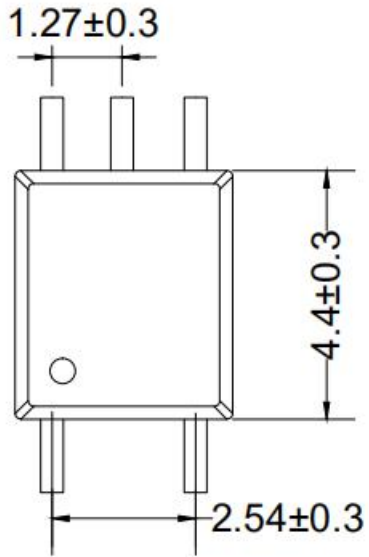

( )

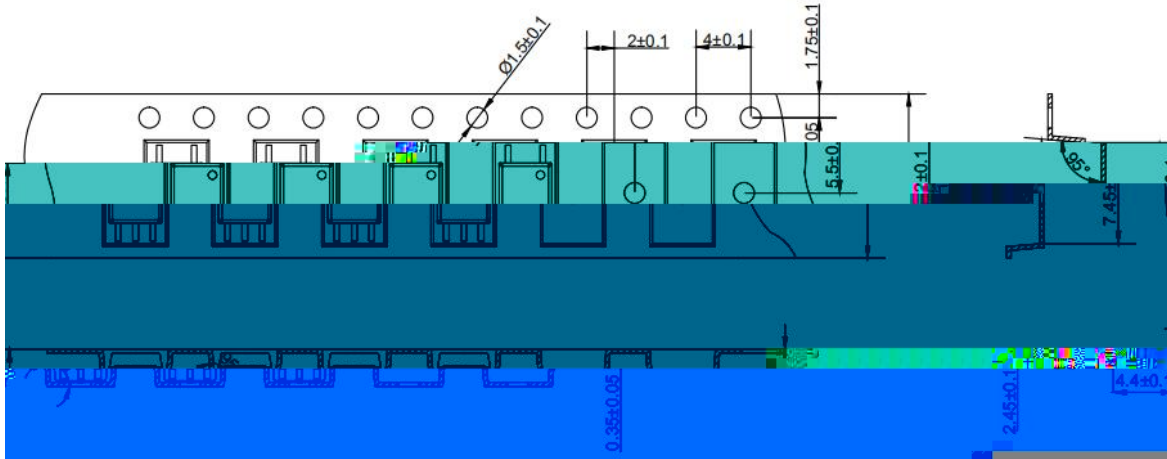

( )

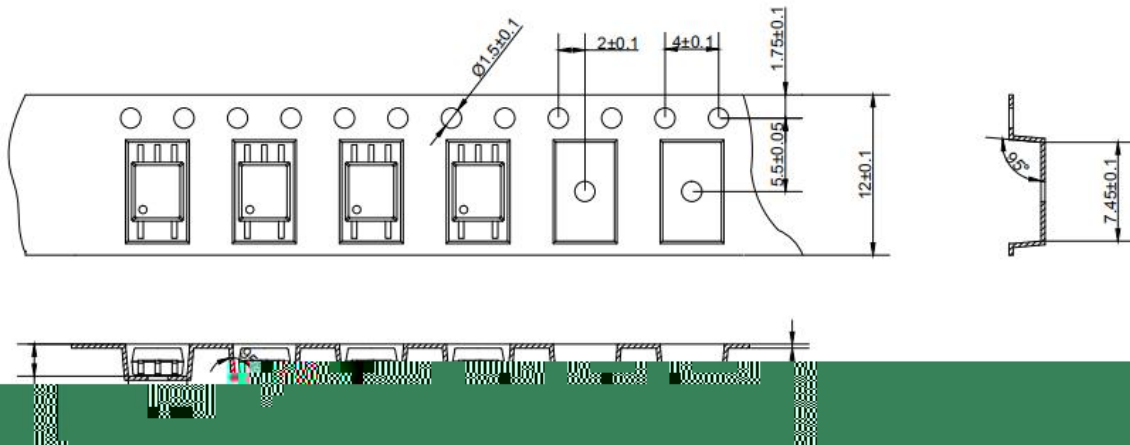



		( )
		( )
		( )
		( )
		( )

( )	
-----	--



**ORIENT**  
ShenZhen Orient  
Components Co.,LTD

Material Code : 120PCXXXXXX

|||||

P/N: OR-XXXXXX

|||||

内箱码

外箱码

Lot No.: XXXXXX-XXXXX-TX-X

|||||

D/C: XXXX

|||||



Qty: XXXX PCS

“XXXXXXXXXXXXXXXXXX” (一体机序列码)

|||||

Made in China

:

	存储				仪	
	低 存储				低 仪	
					冷 冲 击	
	 冲击				冷 冲 击	
	作				仪、 化	
	人体				仪	
	可					
	寿命				仪	
	压力				压力	

( )

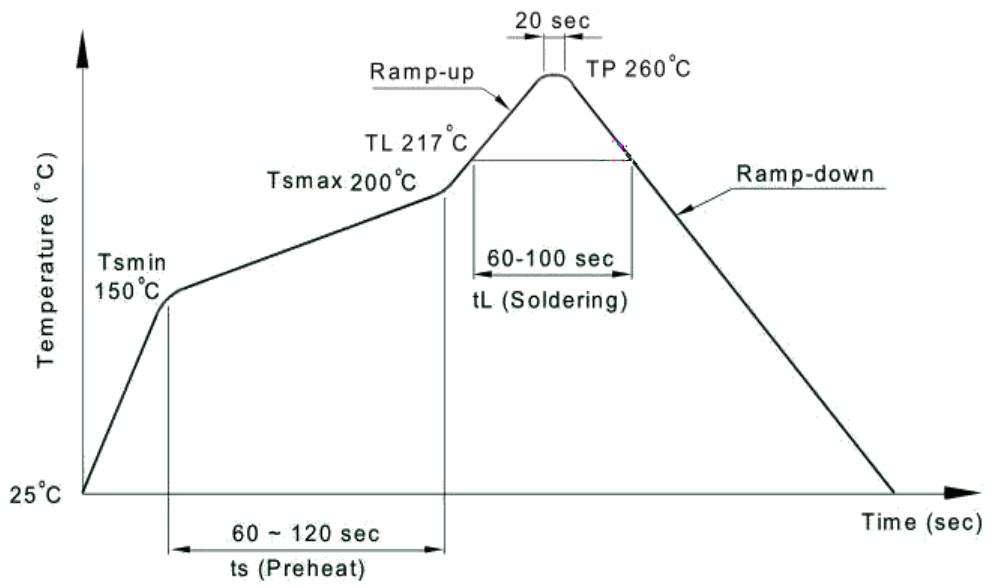
( )

( )

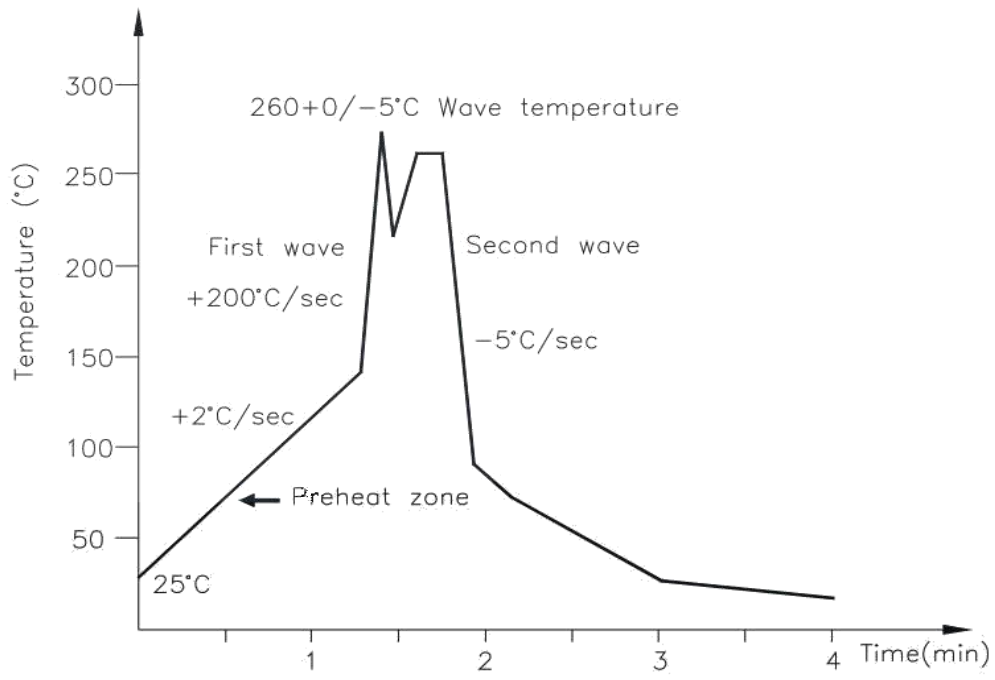
--	--

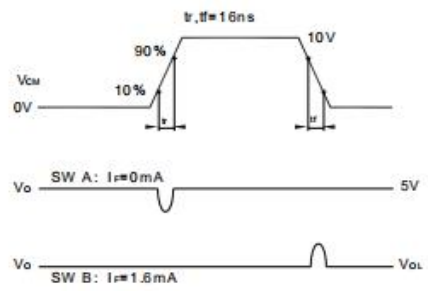
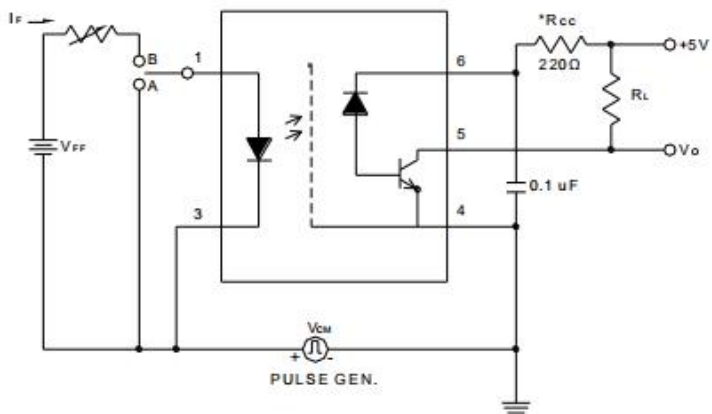
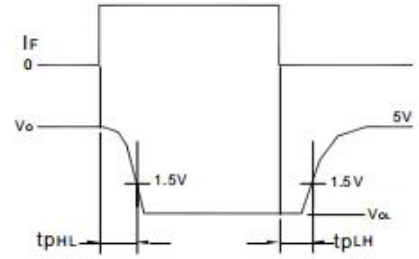
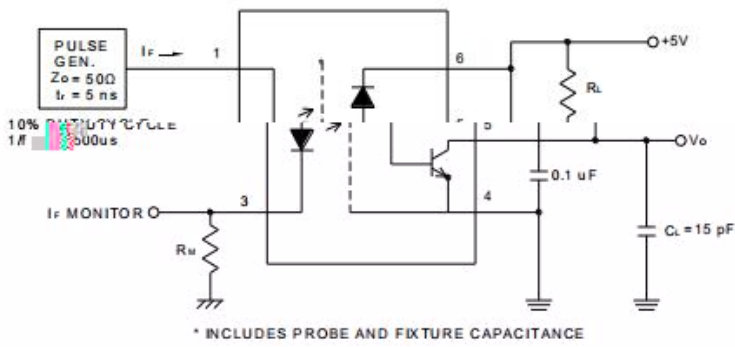

Figure 3: DC and pulsed transfer characteristics

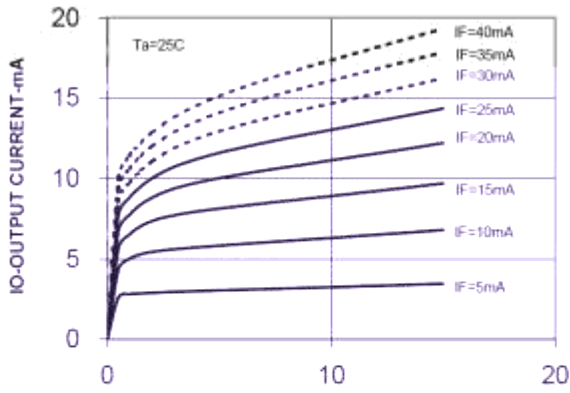

Figure 6: Current transfer ratio vs. input current

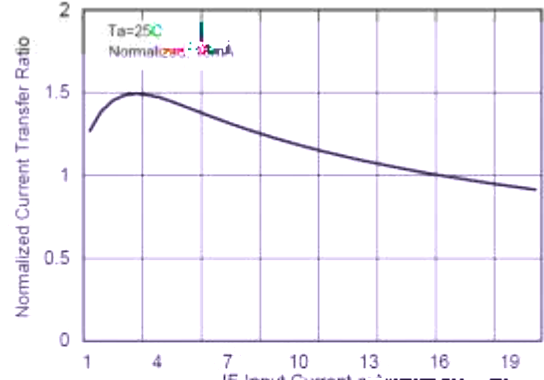

Figure 7: NORMALIZED CURRENT TRANSFER RATIO VS. AMBIENT TEMPERATURE

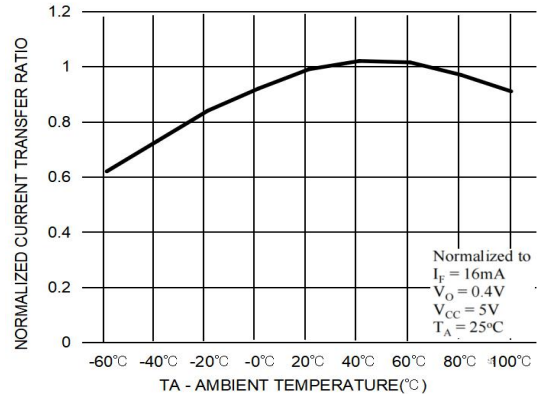

Figure 5: Logic high output current vs. temperature

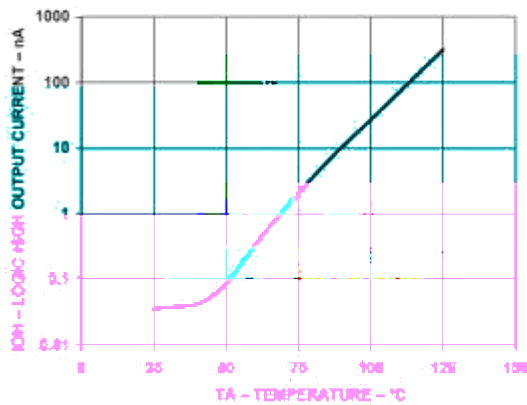

Figure 8: Small-signal current transfer ratio vs. quiescent current

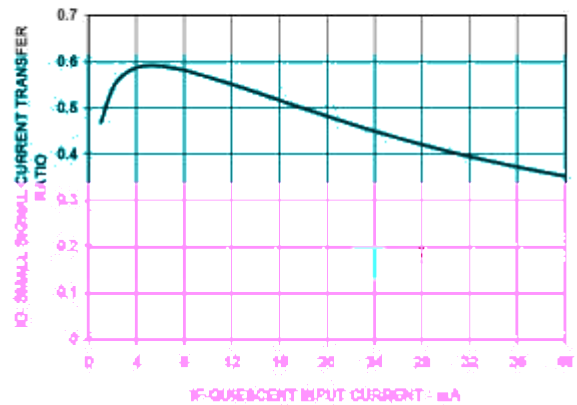

Figure 9: Propagation delay time vs. temperature

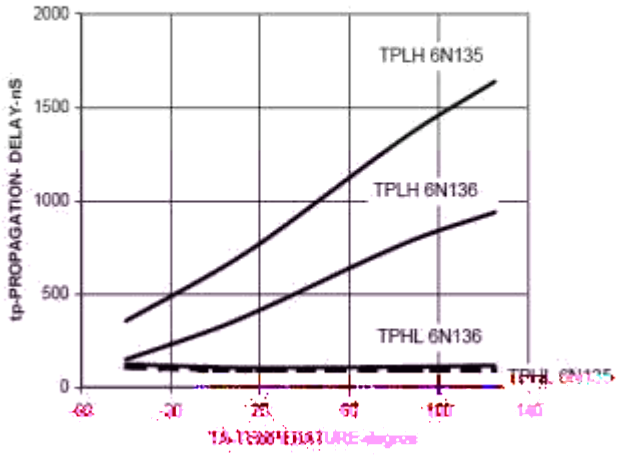

Figure 10: Propagation delay time vs. load resistance

